

INDAG

Maschinenbau GmbH

The FlowMix[®]-Company

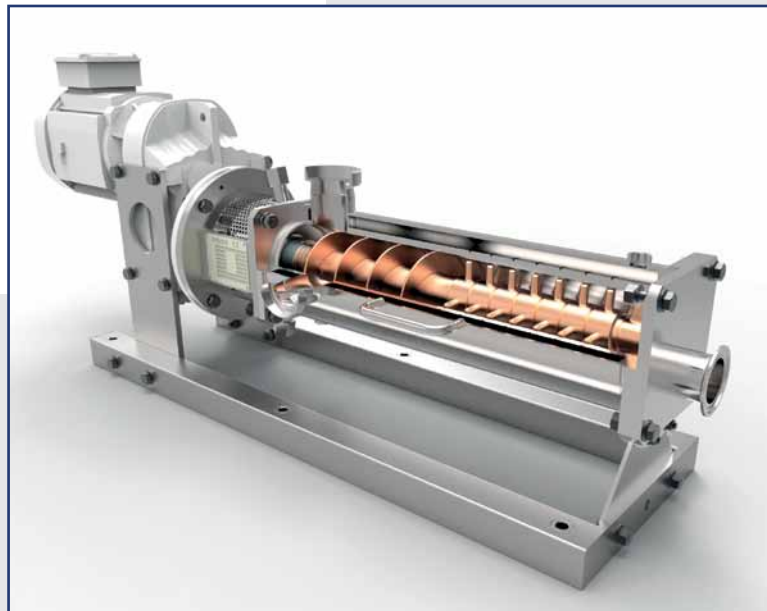

**Continuous solid-liquid mixer
Type DLM/FS**

For gentle mixing

■ Function and application of DLM/FS

INDAG solid-liquid mixer type DLM/FS is used for continuously mixing of liquids with solid components. Solid components could be from fine powder up to 20 mm particle size. Usually share of liquid is higher compared to share of solid component. Mixing process in INDAG DLM/FS is very gentle. Particles and shear sensitive liquids – like foams – will not be damaged.

A few examples of applications are: Mixing of chocolate – nuts; fruit jelly – crispies; candy mass – citric acid powder; whipped cream – chocolate pieces; fresh cheese – herbs/spices;

■ Technology of DLM/FS

INDAG solid-liquid mixer consists of a feeding zone (a helical screw) and a mixing zone (rotor with round mixing elements). Liquids and solid components will be metered into feeding zone. Helical screw will feed components into the mixing zone. Inside mixing zone all components will be gently and homogeneously mixed. At outlet connection mixture will flow almost pressure less (max. 0,5 bar) into a hopper or feeding pump. Stator and rotor can be executed with double jacket for heating or cooling. INDAG DLM/FS mixer can be CIP cleaned. Dynamic sealing can be a double acting mechanical seal or a food grade stuffing box seal.

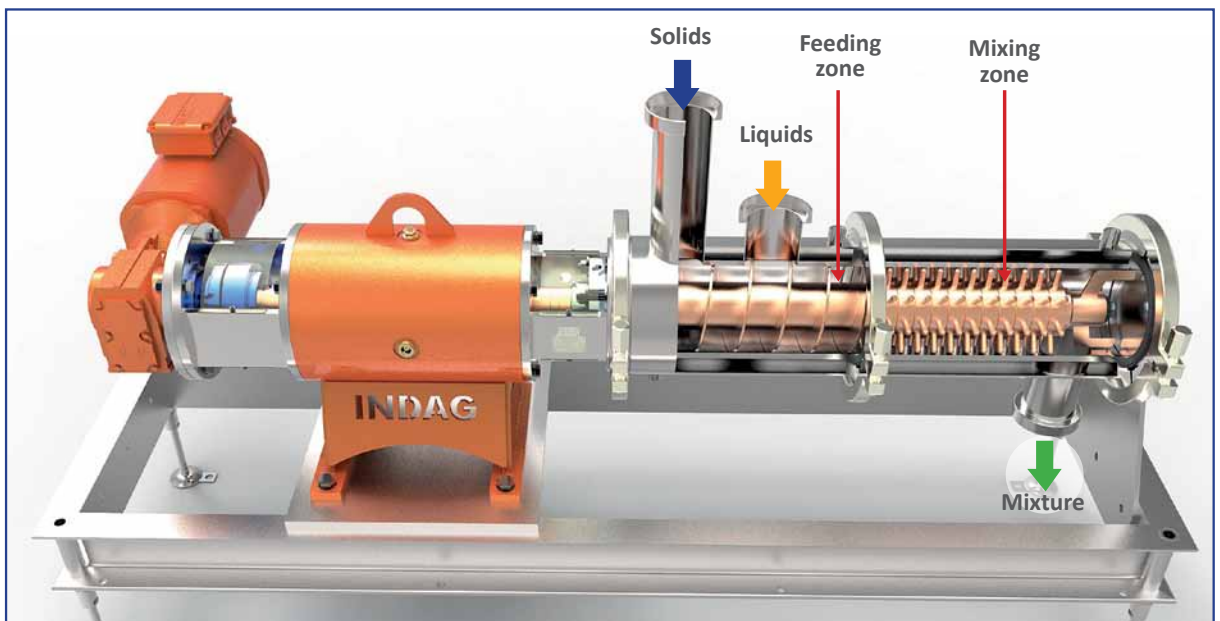

Construction of
INDAG
DLM/FS-Mixer

■ Advantages of DLM/FS

- Very good self cleaning during CIP-cleaning
- Homogeneously mixing of small concentrations (0,1% mixing ratio); very homogenous mixing result.
- Energy efficient mixing process
- Mixing energy can be changed by frequency inverter
- Temperature increase less than 1°C
- Gentle mixing of shear sensitive products
- Easy dismounting for manual cleaning

Positioning

horizontal

Pressure levels

6 bar, DLM/FS mixer creates max. pressure of 0.5 bar, depending on viscosity of mixture.

Materials

1.4301 (AISI 304), 1.4404 (AISI 316 L)

Seals

Double acting mechanical seal;
stuffing box seal

Connections

Dairy connections according to DIN 11851, DIN 11864,
Tri Clamp, SMS

Rotational speed

100 rpm to 300 rpm

Capacities

100 l/h to 7.000 l/h

Temperatures

0 °C to 150 °C

Viscosities

1 mPas to 100,000 mPas

■ Flow diagram of DLM/FS

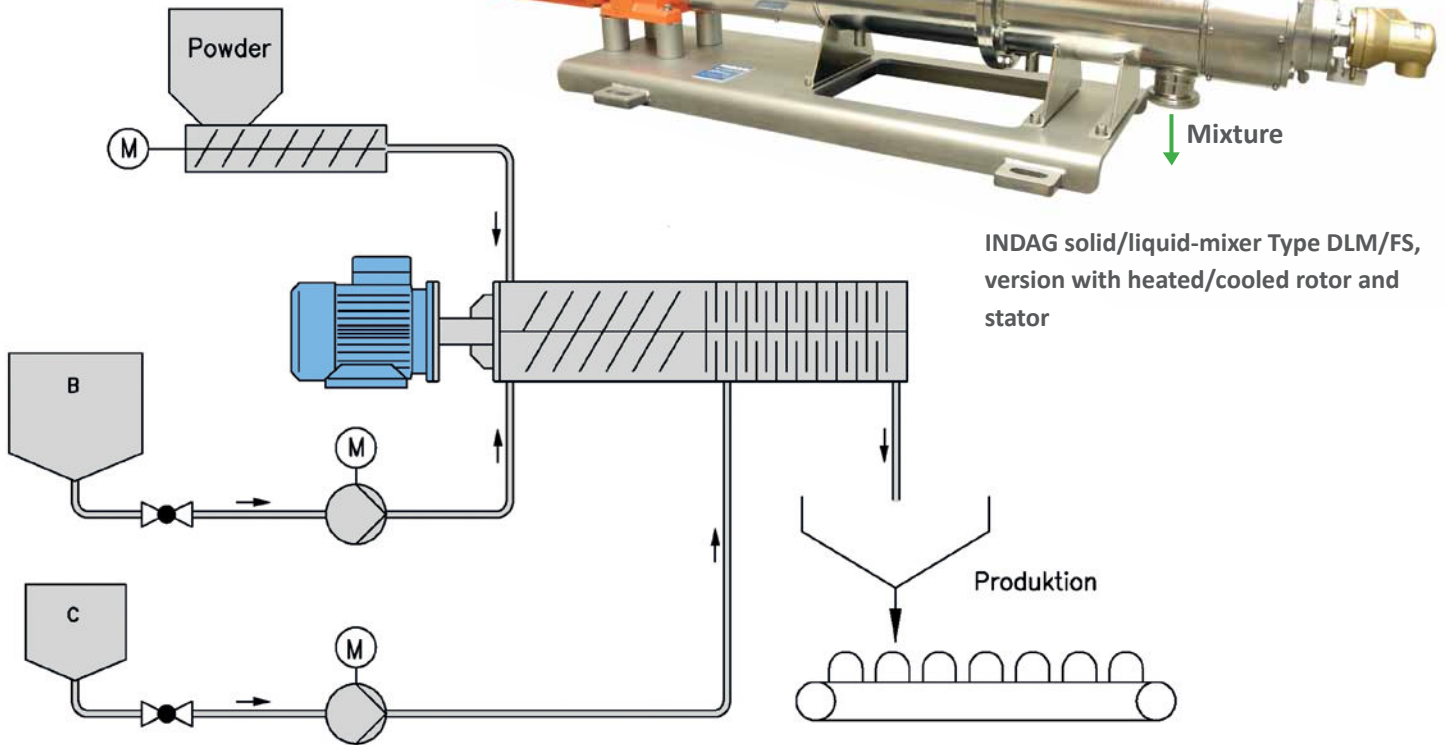

■ Mixer capacities of DLM/FS

Type DLM/FS	unit	2	3	4	5
capacity*	l/h	100 - 800	500 - 2,000	1,000 - 3,600	1,500 - 7,000
connection	mm	65	80	100	150
optional	Inch	2.5"	3"	4"	6"
power*	kW	1.5 - 2.2	2.2 - 4	4 - 7.5	5.5 - 11
rotational speed*	1/min	150 - 300	150 - 300	100 - 200	100 - 200

*depends on Produkt



Mixing elements



INDAG solid/liquid-mixer type DLM/FS

■ Dimension drawing of DLM/FS (KB)

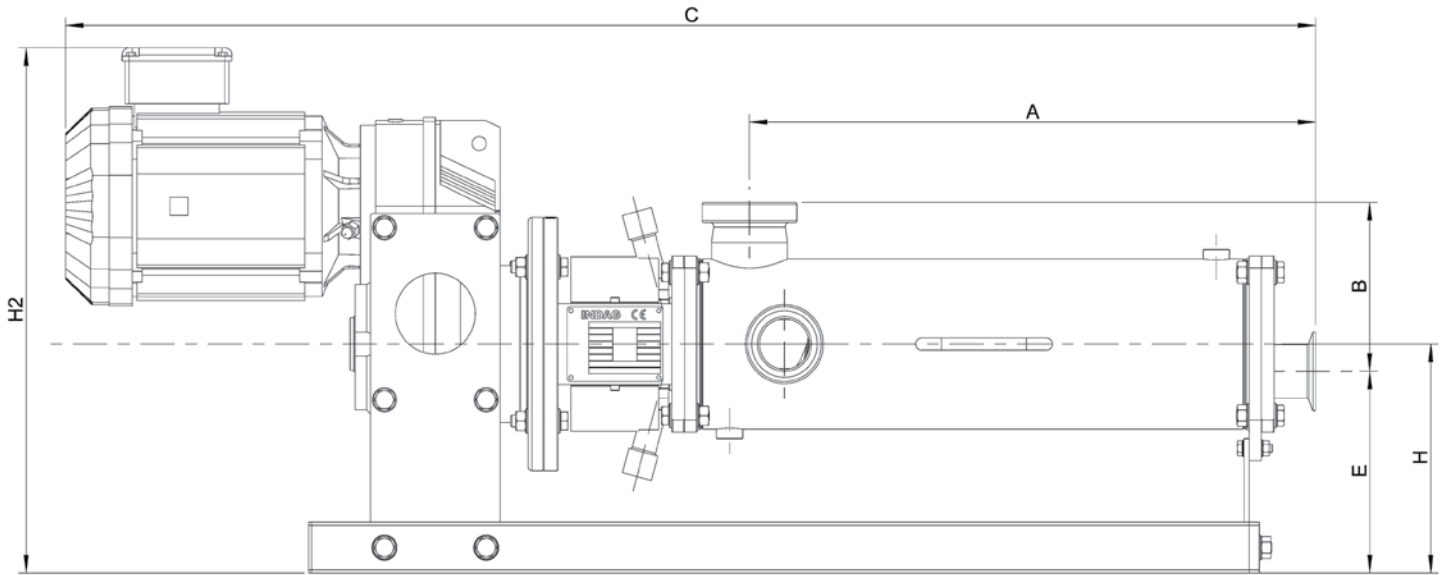

■ Dimension table of DLM/FS

Type	unit	A	B	H*	C*
DLM/FS-206	mm	568	167	226	1253
DLM/FS-306	mm	586	200	276	1388
DLM/FS-408	mm	666	248	335	1468
DLM/FS-508	mm	692	292	385	1590

* depends on the drive

Company profile

For over 60 years INDAG develops, designs and produces dynamical inline mixers and complete metering and mixing systems in Borsfleth, Germany.

INDAG products claim to meet highest requirements in quality and efficiency.

INDAG

Maschinenbau GmbH

Ivenfleth 13

D-25376 Borsfleth / GERMANY

phone +49 4124 9876-0

fax: +49 4124 9876-54

e-mail: info@indag.de

www.indag.com

Product and service spectrum

Product spectrum includes: dynamic inline mixer type DLM/M, intensive inline mixer type DLM/P, intensive inline mixer type DLM/S, homogenizer type DLM/H, solid-liquid mixer type DLM/FS, complete systems type FlowMix for metering, mixing and aerating. Complete systems are equipped with PLC control and sensors for automatic and monitored production. Service spectrum includes commissioning and maintenance of mixers and complete systems.



NORTH AMERICAN PARTNER ORGANIZATION:

NORTH AMERICAN PROCESS, INC. d/b/a INFINI-MIX Process Solutions

811 EAST MAPLE STREET
MORA, MN 55051
(855) PROCESS (776-2377)
678-614-5112
www.WeMixStuff.com
Sales@naprocess.com